

Rohrendkappe, kurz

- kurzes Schweißende

optional: mit Rohr verlängert

End cap, short form

- short welding end

optional: extended with pipe

2025 #1 | EK2

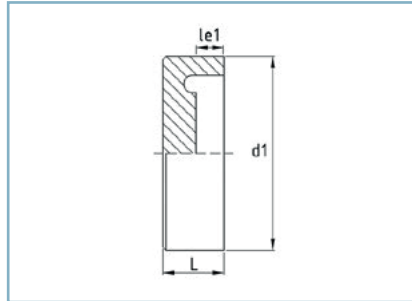

DVGW:
DV-8606BT0423 (Ø 75 mm - Ø 225 mm)
DV-8611BT0424 (Ø 250 mm - Ø 630 mm)

SDR ≥ 41 33 26 21 17,6 **17** 13,6 11 9 7,4 6 ≤ 5

d ₁	l _{e1}	L	Gewicht weight		Euro/Stck. Euro/pc. PE 100
			kg		
50	17	25	0,02		
63	15	25	0,04		
75	14	25	0,1		
90	16	30	0,1		
110	19	35	0,2		
125	17	35	0,3		
140	15	35	0,3		
160	17	40	0,5		
180	19	45	0,7		
200	16	45	1		
225	17	50	1,4		
250	19	55	1,9		
280	19	60	2,7		
315	19	65	3,7		
355	19	70	5,2		
400	17	75	7,4		
450	20	85	10,5		
500	18	90	14,2		
560	19	100	20		
630	19	110	28,3		
710	26	130	33,5		
800	23	140	47,5		
900	28	160	66		
1000	28	175	106		
1200	29	205	184		
1400	30	235	290,2		
1600	35	270	435,8		

Rohrendkappe, kurz

- kurzes Schweißende

optional: mit Rohr verlängert

End cap, short form

- short welding end

optional: extended with pipe

2025#1 | EK2

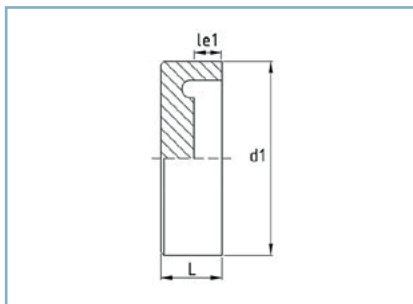

DVGW:
DV-8606BT0423 (Ø 75 mm - Ø 225 mm)
DV-8611BT0424 (Ø 250 mm - Ø 630 mm)

SDR ≥ 41 33 26 21 17,6 17 13,6 **11** 9 7,4 6 ≤ 5

d ₁	l _{e1}	Gewicht weight		Euro/Stck. Euro/pc. PE 100
		L	kg	
50	15	25	0,02	
63	19	30	0,1	
75	17	30	0,1	
90	14	30	0,1	
110	16	35	0,2	
125	18	40	0,3	
140	16	40	0,4	
160	17	45	0,7	
180	14	45	0,9	
200	15	50	1,2	
225	16	55	1,7	
250	17	60	2,3	
280	17	65	3,2	
315	16	70	4,4	
355	19	80	6,4	
400	16	85	8,9	
450	17	95	12,7	
500	19	105	17,4	
560	19	115	24,1	
630	17	125	33,9	
710	28	150	47	
800	27	165	67	
900	30	185	95	
1000	38	210	131	
1200	34	240	224	
1400	29	270	350,5	
1600	30	305	522,3	